

UP-X300

Hospitality POS Solution



UP-X300

Hospitality POS Solution

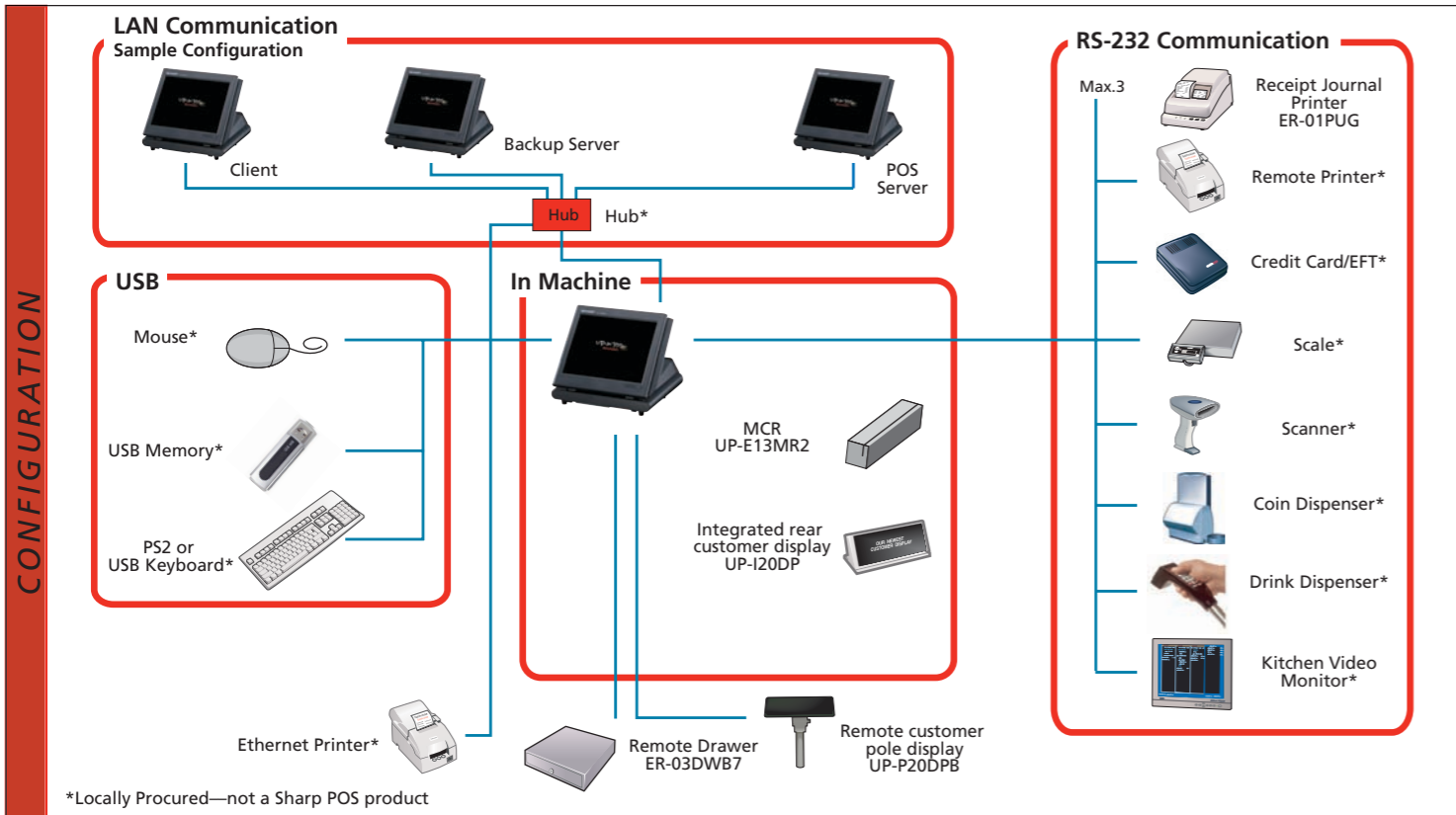

Point of Sale • Point of Sale • Point of Sale • Point of Sale • Point of Sale



Powerful
Flexible
Reliable

*Technology for
Exceptional
Customer Service*

OPTIONAL ACCESSORIES

ER-01PUG	2-station thermal printer
UP-I20DP	Integrated 2-line 20-character customer display
UP-P20DPB	2-line 20-character remote customer pole display
UP-E13MR2	Magnetic stripe reader
ER-03DWB7	7B/5C Cash drawer
ER-75CC3	Coin case ER-03DWB7

For further details about additional options not listed below, contact your Sharp dealer.
Note: You cannot use the UP-I20DP and the UP-P20DPB simultaneously.

TERMINAL DIMENSIONS

Dimensions (W x D x H)	12.5" x 12.2" x 11.2"
Weight	12.6 lbs.

CASH DRAWER DIMENSIONS

Dimensions (W x D x H)	17.5" x 18.1" x 4.09"
Weight	19.0 lbs.

SPECIFICATIONS

Operator Display	12.1-inch TFT color LCD (XGA) with backlight
Keyboard	Analog touch screen and optional external support
Resolution	1024 x 768 dots
Drawer Ports	2 -drawer support (optional)
CPU	VIA Eden ESP 7000
CompactFlash Memory	128 MB
DRAM Memory	128 MB standard
Ethernet LAN	TCP/IP 10Base-T/100Base-TX
I/O Ports /External Bus	(3) RS-232 x 3 (1) VGA (1) Customer Display (2) USB 2.0 x 2 (2) Drawer (1) PS2
Recommended System Configuration	Up to 6 terminals
Power Source	43 W (operating)
Power Consumption	120V AC ±10% AC, 60Hz

Design and specifications are subject to change without notice.

© 2005 Sharp Electronics Corporation. Sharp is a registered trademark of Sharp Corporation. Windows® is a registered trademark of Microsoft Corporation in the United States and other countries. All other trademarks are the property of their respective owners.



SHARP ELECTRONICS CORPORATION
Information Systems Group / POSD
Sharp Plaza, Mahwah, N.J. 07430-1163
1-800-BE-SHARP
www.sharppusa.com/pos

ECR-1029 September 2005 Rev. 2.0

September 2005 Rev. 2.0

Information Systems Group



Your goal is to deliver consistent, quality service to your customers every time they visit your establishment. The Sharp UP-X300 Point-of-Sale offers exceptional power, flexibility and reliability to help you satisfy your most demanding customers and keeps them coming back for more. This sleek, compact and complete hardware/software solution is designed for a variety of hospitality environments including bars, delis, cafeterias, as well as independent table service and fast casual restaurants. The UP-X300 provides the unique capabilities you need to run your business efficiently and at a low cost of ownership.

Increase Sales and Profits

A complete system that can help you make more money. The Sharp UP-X300 POS speeds service so you can turn tables faster. It easily supports promotions and combinations, all the while providing tighter controls over inventory and cash.

Serve Customers Quickly

The Sharp UP-X300 POS is built for speed. Time-saving features like lead-through order entry, drag-and-drop bill and item splitting and real-time table status help you seat, serve and check out customers fast and efficiently.

Train Employees in Minutes

Gone are the week long learning curves. Your employees are ready to use the system with minimal training. An enhanced graphical user interface, brilliant 12.1-inch color LCD touch screen and customized multi-task flexible frame layout, make the Sharp solution simple to use because it's designed by you to fit your business.

Enhance Business Control

With the Sharp solution, you'll always know what's going on in your restaurant. Snapshots of real-time table status, open checks and sales provide a quick view of the business, enabling you to make decisions faster.

Operate More Efficiently

The Sharp UP-X300 is what you need in one system. Customer service and management functions customized for your restaurant, as well as integrated connections to all important peripheral devices, help you keep operations running smoothly.

Powerful

Powerful POS technology for the ultimate in speed, efficiency and control.

The Sharp UP-X300 POS offers an ideal combination of advanced customer service features and management functions as standard components of the system.

For Faster Service:

Enhanced graphical user interface

- Highly customizable restaurant layout
- Item images on buttons
- User-friendly navigation

Advanced table management

- Table attributes, such as smoking, non-smoking, reserved or joined
- Real-time table status, such as no order, starters, main and payment
- Integrated reservations function including Automatic Table Search

Guest check management

- Simple "drag-and-drop" bill and item splitting
- Guest check tracking (from bar to table)
- Repeat round entries
- Table assignment of cash bar orders
- Associate bar tabs with customer names for recalls

Modifiers, promotions and combinations

- Lead-through order entry with up to five menu levels
- Preprogrammed promotions by time of day (e.g. happy hour)
- Multiple items matched and sold together functions

For Stronger Management Controls:

Cash Management and Control

- Real-time sales tracking at the POS
- Electronic Funds Transfer (EFT) without a back-office PC

Employee Management

- Server sales and tip management
- Instant messages to servers displayed on the POS

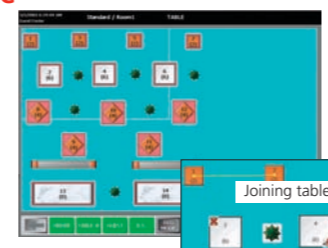

View table attributes and real-time status with one touch.

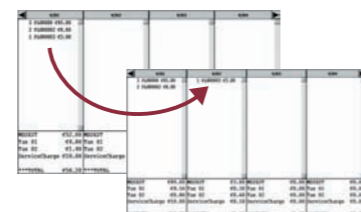

Split checks and items quickly and easily.

Flexible

Expandable, customized POS solutions to meet the specific needs of your restaurant.

The Sharp UP-X300 POS adapts to your way of doing business. Many of the solution's features can be easily configured to provide you with the personalized tools you need to improve customer service, efficiency and control.

Tailored Screen and Menu Layout

With a virtually unlimited ability to customize the POS screen design and menu layout, the Sharp UP-X300 POS makes it easier for your employees to serve customers and for you to manage the business.

Customized Multi-Task Frames

Sharp's unique multi-task frame technology allows you to divide the POS screen frames, each with a different feature of your choice. With access to the restaurant layout, item menu, receipt and much more on a single screen, your employees can move from task-to-task quickly and efficiently.

Robust Peripheral Support

Support for peripherals and interfaces to complementary software systems you need to run your business are built into the Sharp terminal as standard components.

Key Optional Peripherals and Software Interfaces:

- Kitchen printers, cash drawers, coin dispensers, scanners and scales
- Integrated 3-track magnetic stripe reader
- Closed-circuit surveillance
- Berg Liquor Systems
- Electronic payment systems (including stored value gift)

Additional Configuration Options

Many individual features can be easily configured to support your business, including:

- Item routing to remote printers
- Table management attributes and status indicators
- Reporting configurations
- User security levels - turn features or screens on/off based on user security profile



Reliable

Dependable restaurant systems from the brand you know and trust.

When it's 7 p.m. on Saturday night and you have a full house, the last thing you need is for your POS system to fail. Sharp understands the importance of reliable restaurant technology and built its solution to minimize service interruptions and help protect your valuable data in the rare event of a problem.

Data Integrity

Sharp systems are built for continuous operation. The Sharp UP-X300 POS will help protect and maintain your critical information with backup data files on a backup system.

All-in-One Solution

A complete hardware and software solution, from one provider. The Sharp UP-X300 POS software and hardware function seamlessly as a single solution and are optimized for harsh restaurant environments.

An Experienced, Trusted Provider

Restaurateurs know Sharp as a technology leader that has successfully served the POS foodservice industry for years. This reputation is built on a long line of exceptionally reliable products that continually meet the unique needs of the hospitality industry. The Sharp UP-X300 POS extends this tradition.

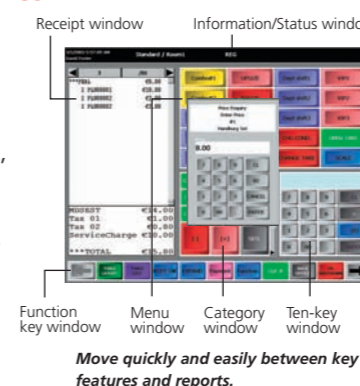

Move quickly and easily between key features and reports.